

# DOUBLE SIDED

## E-Smart

### INSTRUCTION MANUAL

Halo 810 DS Halo 1030 DS		
-----------------------------	--	--

## CONTENTS

EU Directives and UKCA Standards.....	3
Important Information and Health & Safety.....	4
Components for Evoflame & E-Smart.....	5
Installation.....	6
Model Dimensions.....	7
Requirements and Checks.....	8
Installation.....	9
Log Layouts.....	11
Installing/Removing the Front Glass.....	13
Troubleshooting.....	14
Warranty & Registration.....	16

Metal - Steel or cast iron	Can be taken to a local recycling centre for reuse to reduce waste going to landfill
Glass & Screens	Can be taken to a local recycling centre for reuse to reduce waste going to landfill.
Vermiculite	Non hazardous material. Vermiculite can be crushed up and used for plant bedding and ash used for composting or disposed of at a local recycling centre for reuse to reduce waste going to landfill.
Electrical components - Fans, heater elements, PCB's, Power pack's, LED's	Dispose at a local recycling centre In accordance with latest WEEE directive.
Log fuel effects	These logs contain refractory ceramic fibre materials which requires disposal in accordance with WEEE legislation.
Natural Wood	Can be taken to a local recycling centre for reuse to reduce waste going to landfill

## EU DIRECTIVES

All Evonic Fires products meet the requirements of the EC Directives. These directives have been met by compliance with the following standards:

EU 2011-65/EU 2015/863 Restriction of Hazardous Substances.

References to the relevant designated standards used:

EN 55014-1:2006 + A1:2009 + A2:2011 Electromagnetic Compatibility.

EN 55014-2:2015 Electromagnetic Compatibility.

EN 61000-3-2:2014 Electromagnetic Compatibility (EMC). Limits. Limits for Harmonic Current Emissions.

EN 61000-3-3:2013 Electromagnetic Compatibility (EMC). Limits. Limitation of Voltage Changes, Voltage Fluctuations and Flicker.

EN 60335-1:2012 + A11:2014 Household and similar electrical appliances - Safety

EN 60335-2-30:2009+A11:2012 Household and similar electrical appliances. Safety. Particular requirements for room heaters

## UKCA STANDARDS

All Evonic Fires products are in conformity with the relevant UK Statutory Instruments (and their amendments).

2016 No. 1101 The Electrical Equipment (Safety) Regulations 2016

2016 No. 1091 The Electromagnetic Compatibility Regulations 2016

2012 No. 3032 The Restriction Of Use Of Certain Hazardous Substances In Electrical And Electronic Equipment Regulations 2012



## IMPORTANT INFORMATION AND HEALTH & SAFETY

When using electrical appliances, basic precautions should always be followed to reduce the risk of fire, electric shock, and injury to persons, including the following:

- Read all of the instructions carefully before using the appliance, only use this appliance as described in this manual. Any other use not recommended by the manufacturer may cause injury to persons, or damage to the appliance.
- Remove all packaging and dispose of it at an appropriate recycling facility.
- When transporting or storing the appliance and power lead, keep in a dry place, away from excessive vibration and store so as to avoid damage.
- This fireplace is hot when in use. To avoid burns, do not let bare skin touch hot surfaces. The trim around the heater outlet becomes hot during heater operation.  
**DANGER:** High temperatures may be generated under certain abnormal conditions.
- Do not install this appliance immediately in front of a fixed socket outlet.
- Do not install this appliance in the immediate surroundings of a bath, shower, swimming pool or any other area where the appliance could come into contact with water or humidity, e.g. a bathroom.
- Do not use in areas where gasoline, paint, or any flammable liquids are used or stored.
- This appliance is only suitable for indoor use, do not use outdoors.
- Do not cover the appliance, or let the air inlet/outlet to be obstructed in any way as it may overheat.
- Keep the power lead away from hot surfaces and the heater outlet. Do not route the power lead in front of the appliance, or under any carpets or rugs.
- A maintenance hatch must be installed into the surrounding installation to allow future access.
- Always use a certified electrician should new circuits or outlets be required. And always use properly grounded, fused and polarised outlets.
- Where the power lead passes through any masonry wall, stone surround etc. ensure that suitable rubber bushes are fitted at any possible wear points.
- If the power lead is damaged do not use the appliance until it has been replaced.
- Do not use any external switching device, timers, or extension leads. Do not connect the appliance to a circuit that is frequently switched on and off by the utility.
- In the event of a malfunction, switch off the appliance, and disconnect it from the mains power supply. Have the appliance inspected by a certified electrician before reusing.
- Do not use the appliance if it is damaged. In the event of any damage to the appliance, please contact the retailer from whom the appliance was purchased.
- Any repairs must only be performed by a certified electrician.
- Extreme caution is necessary when any heater is used by, located near children or people of reduced mobility, and whenever the unit is left operating and unattended.
- Young children should be supervised to ensure that they do not play with the appliance.
- Disconnect from the power supply before performing any cleaning, maintenance or relocation of the unit. Do not use steam cleaners, or aerosols near the appliance.
- Do not burn wood or anything else in this appliance.
- Do not strike the glass.
- Do not drill or screw any new holes into the appliance.

## COMPONENTS

Model	Log Sets & Quantity		Glass Stones Clear & Amber	Black Vermiculite	Suction Lifter	Electrical Lead	E-Series Instruction Manual
	Woodland or Silver Birch						
Halo 1030 DS	4 x large		4 x Clear 4 x Amber	5 x	1 x	1 x	1 x
Halo 810 DS	4 x small		2 x Clear 2 x Amber	4 x	1 x	1 x	1 x

# INSTALLATION

## MODEL DIMENSIONS



Scan the QR code for more detailed specification drawings.

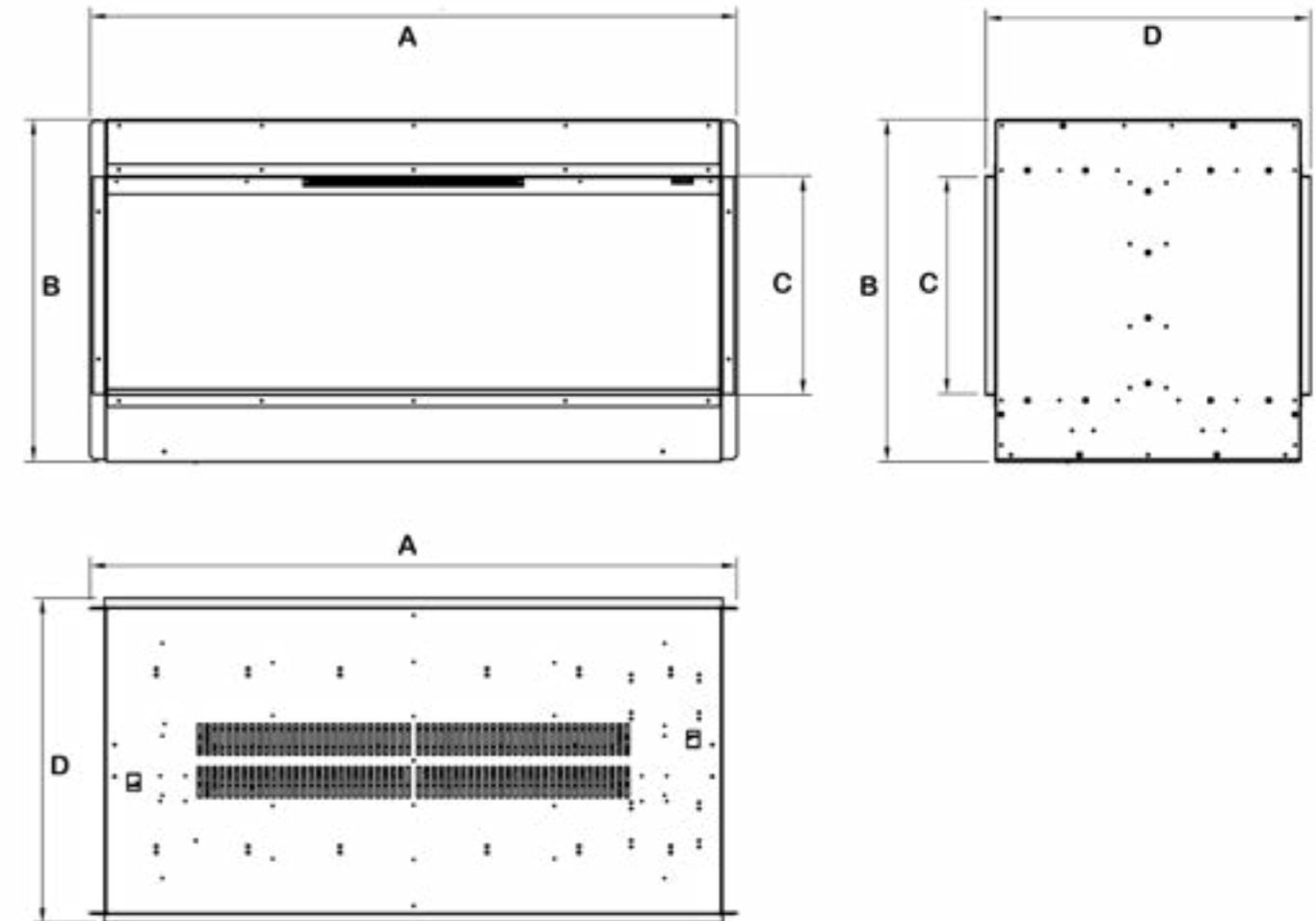

Model	Width		Height		Depth
	Overall unit (A)	Overall unit (B)	Openings (C)	Overall unit (D)	
Halo 1030 DS	1056mm	558mm	355mm	530mm	
Halo 810 DS	864mm	1208mm	1002mm	535mm	

## INSTALLATION

### INSTALLATION REQUIREMENTS

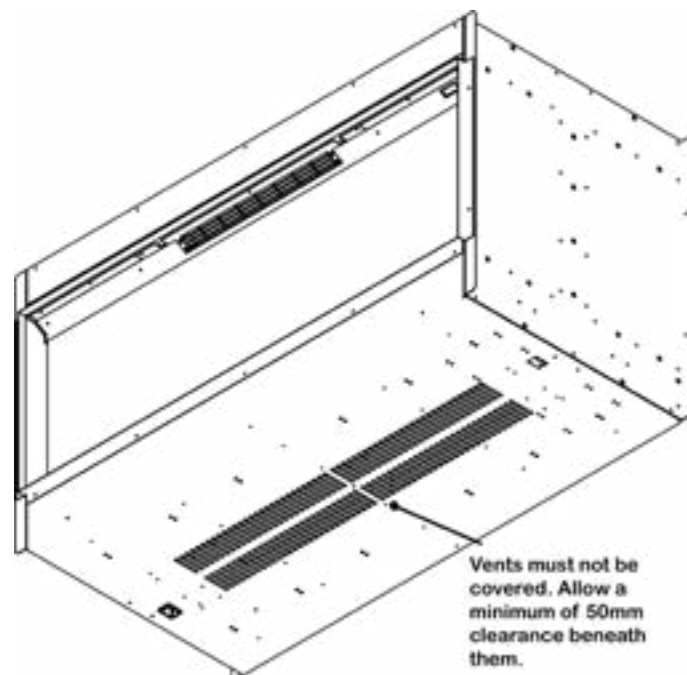

Before installing the appliance please read and take into account the following important requirements;

- Consult a qualified professional to check the structure of the installation site.
- The appliance must not be installed anywhere that it may come into contact with water, i.e. a bathroom.
- Do not use silicones or adhesives to seal in the appliance, and do not apply wet plaster directly to the appliance.

### CHECKS BEFORE INSTALLATION

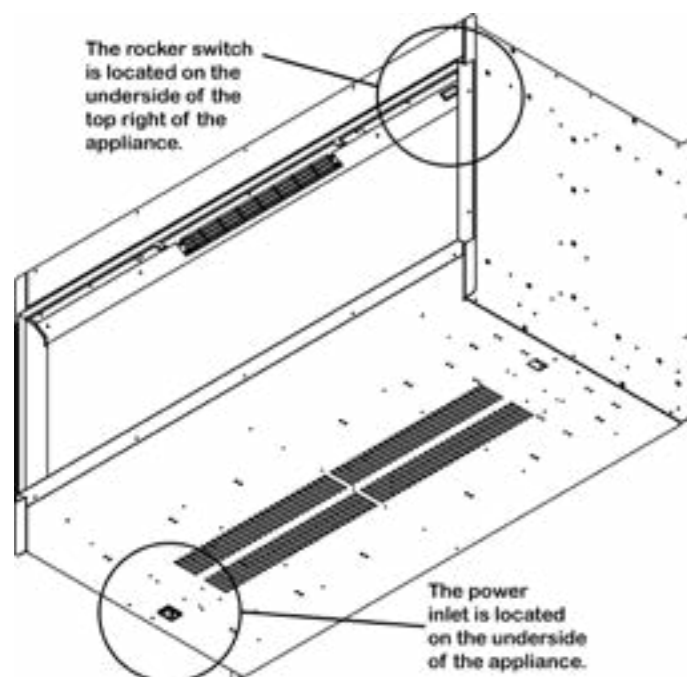

We recommend turning on the appliance before installation, connect the appliance to a power source using the provided electrical lead, and depress the right side of the rocker switch.

Remove the electrical lead from the wall and continue with the installation.

### TOOLS REQUIRED

- Tape Measure
- Pencil
- Spirit Level
- Screwdriver
- PZ2 Screw Bit

### INSTALLATION STEPS

- 1** Remove the two bottom mounted transit brackets from both sides. You will not need these for the installation.

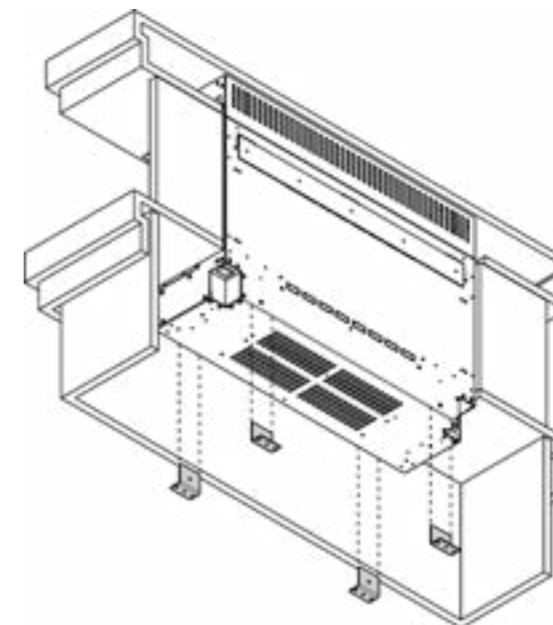

- 2** Determine the finished height and position that you want the appliance to be located. Build your base support taking into consideration the 50mm ventilation gap under the appliance. Then place the appliance onto the support and check that it is well supported.

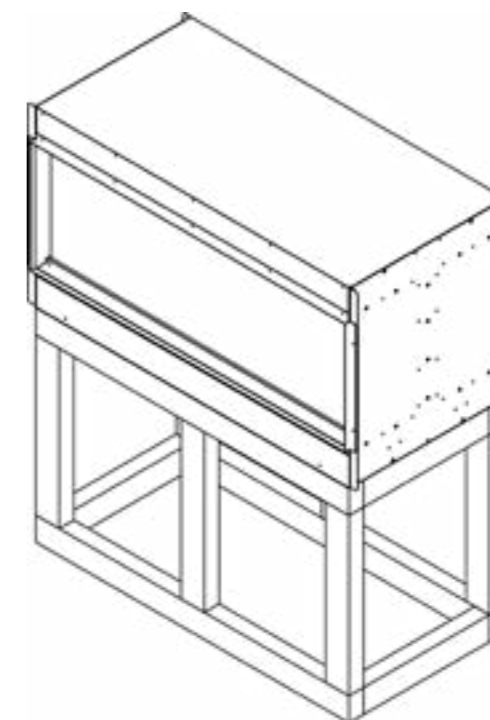

3

Your plasterboard can now line up with the plaster kits on the edge of the appliance.

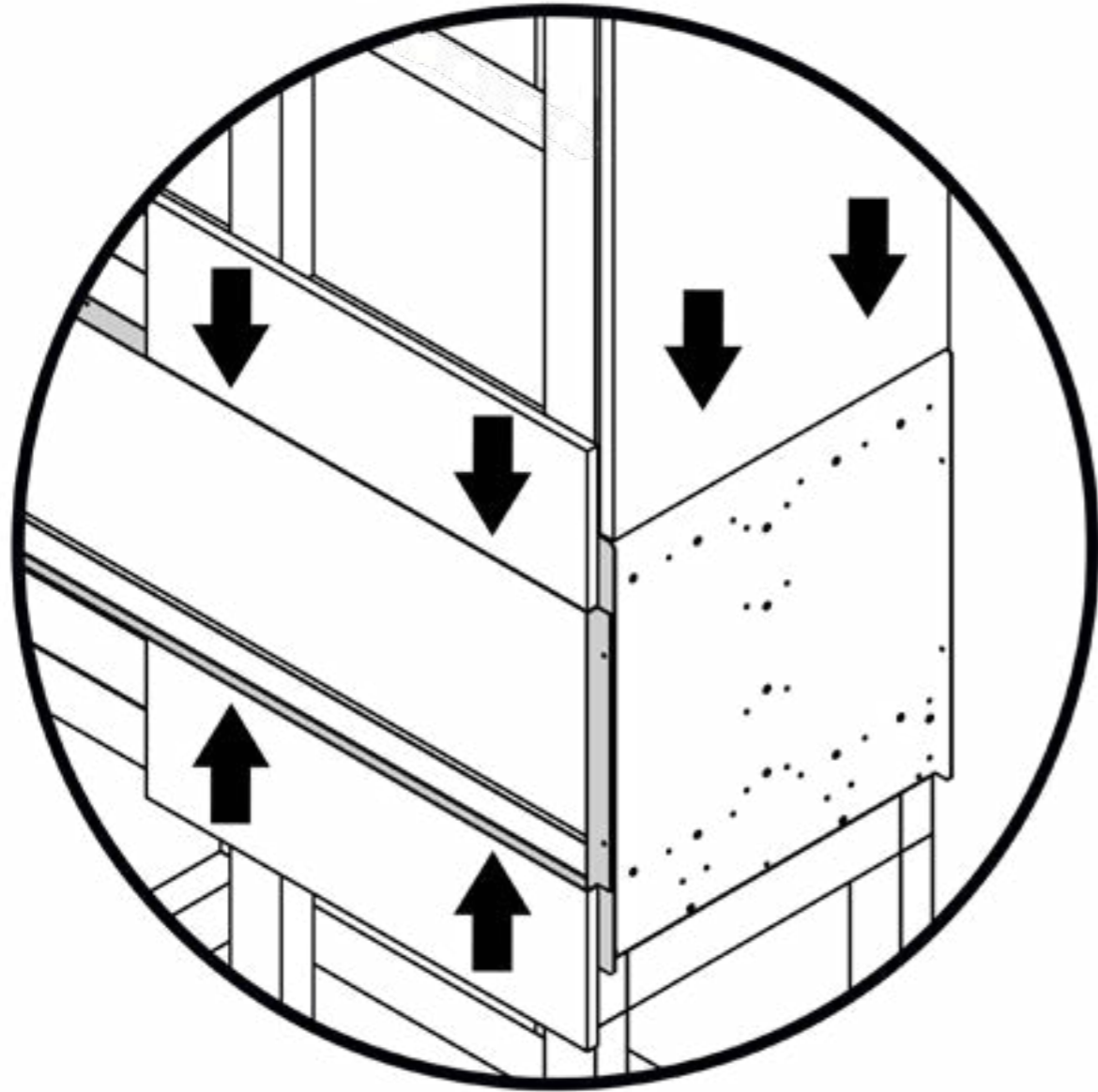

4

Your installation is now complete and you can set up your logs.

---

## LOG LAYOUTS

---

## LOG LAYOUTS

When you have your appliance installed you can set up your log sets. If your model comes with Chippings, Glass Stones and/or Vermiculite lay this on the fuel bed first, then continue with laying out your logs. The following images show an example of how you could lay them out.



4 x Small Woodland / Silver Birch  
Halo 810 DS



4 x Large Woodland / Silver Birch  
Halo 1030 DS

## INSTALLING / REMOVING THE FRONT GLASS

1

Unscrew and remove the glass retainer panel.

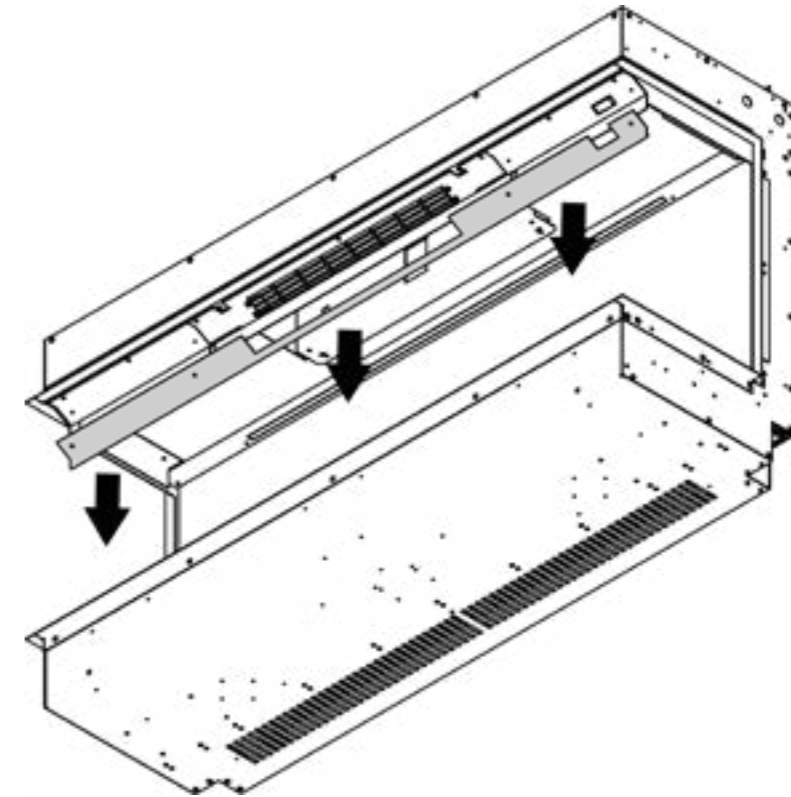

2

Apply the Suction Lifter to the glass and place the bottom edge in first, then angle the top edge into the appliance. Then replace the top retainer panel.

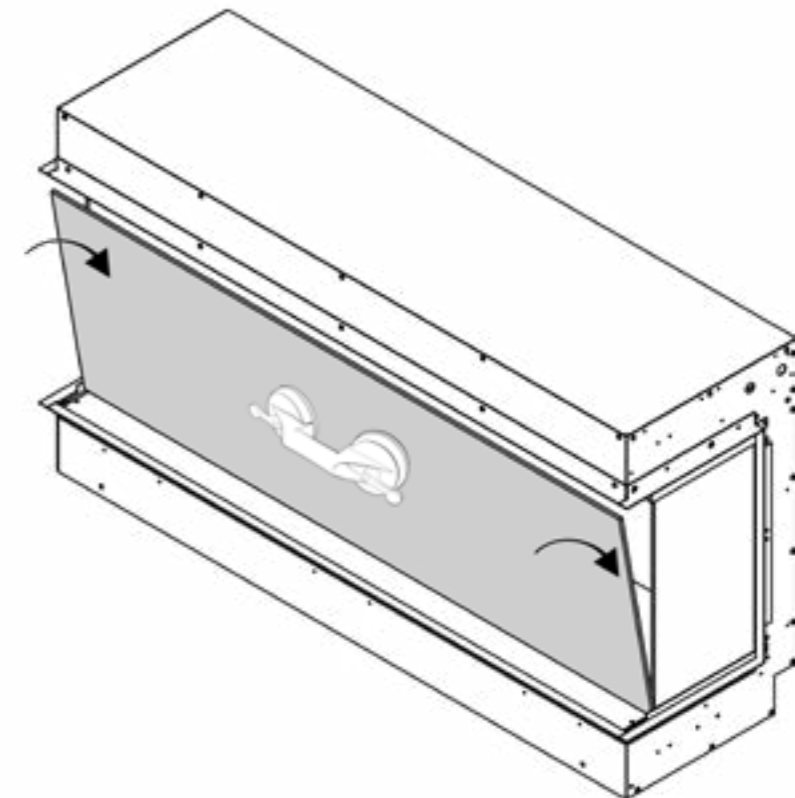

---

# TROUBLESHOOTING

---



## Evoflame Only - LED Strip Replacement

Scan the QR code to be taken to a video in our maintenance series.

Please note; this video shows an old method of removing the front glass panel. Refer to page 25 for the new method.



## Fan Re-setting & Replacement

Scan the QR code to be taken to a video in our maintenance series.

Please note; this video shows an old method of removing the front glass panel. Refer to page 25 for the new method.



## Heater Access & Replacement

Scan the QR code to be taken to a video in our maintenance series.

Please note; this video shows an old method of removing the front glass panel. Refer to page 25 for the new method.



## E-Smart Only - E-Smart LED Replacement

Scan the QR code to be taken to a video in our maintenance series.

Please note; this video shows an old method of removing the front glass panel. Refer to page 25 for the new method.

## REPORT A FAULT

If you have any difficulties or problems with your appliance then please get in touch so that we can assist you. Please scan the QR code to be taken to our websites Report a Fault page, we will then be in touch with you shortly.





## WARRANTY

### Evonic Fires 5-year warranty – 1 year parts & labour + 4 years parts supplied.

The above warranty terms and conditions, as of **1st May 2022**, are applicable for all relevant products purchased after this date. Appliances despatched prior to this date will have an alternative warranty as set out within the Installation and User Instructions that was supplied with the product, this was usually a standard 2-year warranty.

To receive your Extended Warranty your Evonic Fires product must have been purchased from an authorised stockist within our Retailer Network and your warranty registered with Evonic Fires through the online form - [evonicfires.co.uk/register-your-product](https://evonicfires.co.uk/register-your-product). The commencement date for the warranty period is the date of purchase.

The product must be adequately serviced and maintained. Evonic Fires provide maintenance call outs at a cost, and information on this can be obtained by contacting our head office. Please see your Evonic Installation Instructions for further information on how to service and maintain your appliance.

During your extended warranty period, only parts supplied or authorised by Evonic Fires can be used to repair your fireplace, and these spare parts can be obtained by contacting our service department at [service@evonicfires.co.uk](mailto:service@evonicfires.co.uk) or calling **01789 263868**.

Consumable items such as glass, screens, LED's, LED boards, filters and power supplies which are either subject to normal wear and tear or parts that require replacement in connection with normal maintenance are not covered within the extended warranty. These items are covered for the first 12 months.

To make a warranty claim, evidence must be supplied to our service department in the form of pictures, videos, or both. Failure to supply evidence to support your warranty claim may invalidate or delay the claim. Any visit by an Evonic Fires engineer will incur a service charge after the first year. We will not accept or reimburse the cost(s) of any third party who undertakes any work carried out on the product or fits parts, unless we have approved such work in advance of it being carried out.

## WARRANTY EXCLUSIONS AND LIMITATIONS

### The Evonic Extended Warranty does not cover:

1. Damage resulting from installation and usage where the appliance has not been installed or used in accordance with the CK Fires Ltd installation and operation instructions, or if the installation does not conform to local building, fire, and safety regulations.
2. Issues with mains/spur connections of power supply.
3. Damage resulting from the product not being adequately maintained. (Please see your CK Fires Ltd Installation and Operating Instructions for further information on how to service and maintain your appliance).
4. Damage caused by unauthorised modifications, use or repair.
5. Damage or defects caused by the product being stored in a damp, unheated environment.
6. Consequential loss (to the extent permitted by the law) relating to other associated products that have not been supplied by CK Fires Ltd.
7. Consequential loss (to the extent permitted by law) related to decorations, furnishings, or other household assets.
8. Removal and re-installation costs.

## WARRANTY EXCLUSIONS AND LIMITATIONS

Repaired or replaced products are covered only for the remainder of the original warranty period. In the event of a claim being made, this must be reported to your retailer or CK Fires Ltd within 14 days of the fault occurring/being noticed. In the event of a product fault occurring during the warranty period years 2-5, CK Fires Ltd will send the appropriate component or goods necessary to rectify the fault, free of charge.

Nothing in the Extended Warranty shall make CK Fires Ltd liable for any or special, incidental, or consequential damages, injury to persons or property, or any other consequential loss beyond the consumer's statutory rights. The liability on these issues is covered by our Terms and Conditions of Sale.

CK Fires Ltd total liability extends only to the purchase price paid for the goods, except where such a limitation is prohibited by statute. CK Fires Ltd, in the event of a warranty claim, reserves the right either to replace the goods in question or to refund the purchase price of the goods. For product sold outside the UK and Ireland, UK law will prevail. The Evonic Fires Extended Warranty does not affect your statutory rights.

### CK Fires Ltd / Evonic Fires

1, Evonic House, Clifford Park, Clifford Lane,  
Stratford-on-Avon, CV37 8HW

Tel: +44 (0)1789 263868 Fax: +44 (0)1789 293080

Email: [sales@evonicfires.co.uk](mailto:sales@evonicfires.co.uk)  
[www.evonicfires.co.uk](http://www.evonicfires.co.uk)

Follow us on:  
Instagram | Facebook | Twitter | LinkedIn  
[@evonicfires](https://www.instagram.com/evonicfires)